

3/16" X 2" SQUARE
NON-FERROUS FRP
TUBING PER EQUIVALENT
MATERIALS LIST

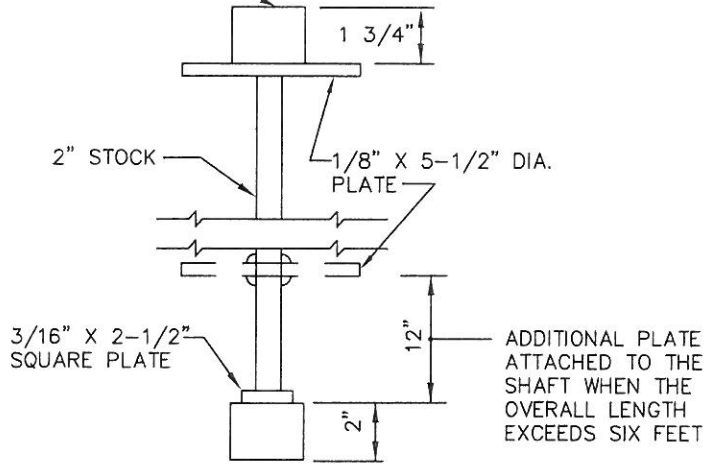

VALVE OPERATOR EXTENSION

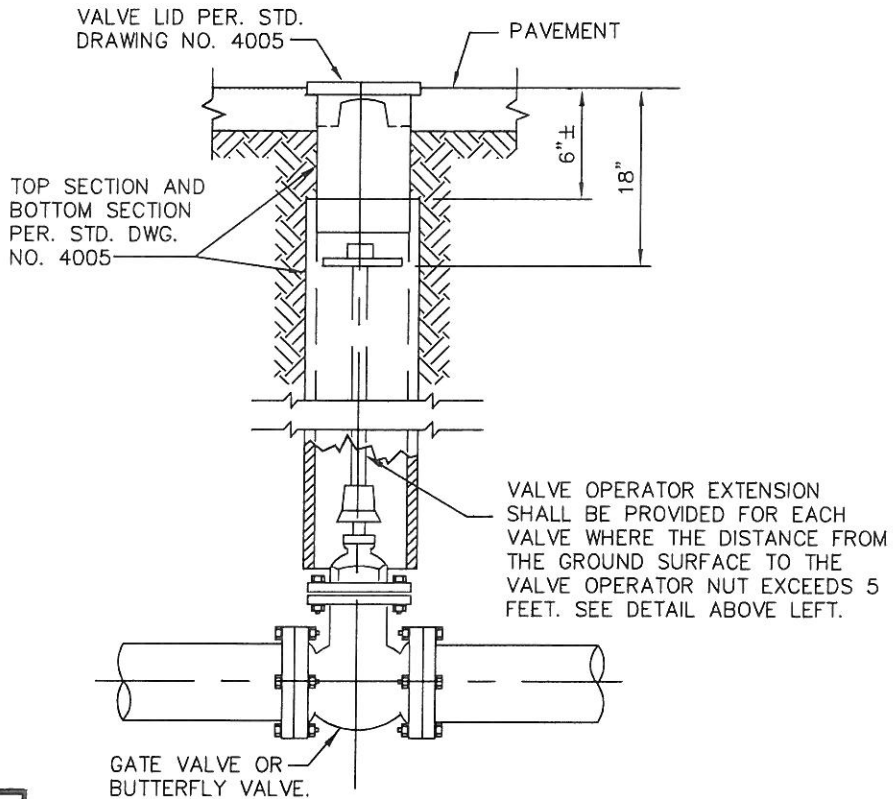

APPROVED BY:				
<i>Louis A. Bi-Younes</i>		11-22-10		44485
LOUIS ABI-YOUNES, CITY ENGINEER	RCE	DATE		
RECOMMENDED:				
<i>Scott Burton</i>		10/25/10		57875
SCOTT BURTON, UTILITIES ENG/OPERATIONS DIRECTOR	RCE	DATE		
REV	DESCRIPTION	BY	APP'D	DATE

CITY OF ONTARIO

VALVE OPERATOR
EXTENSION

STANDARD
DRAWING
NUMBER

4110